

SECTION A-A

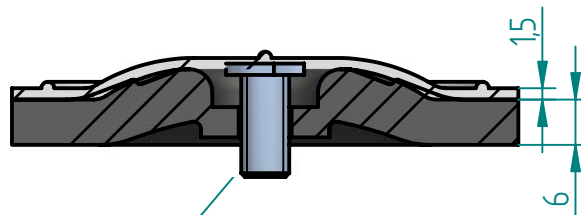

1/4" - 20 UNC (INSERT SCREW)

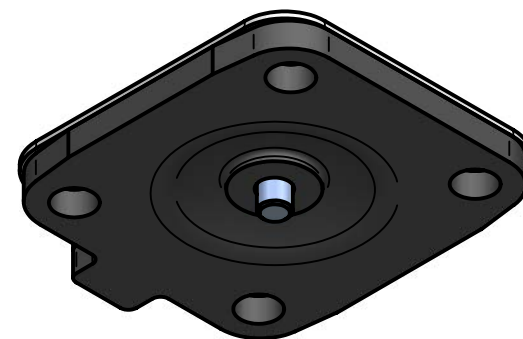
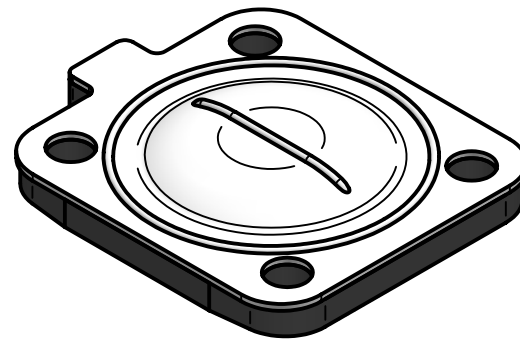

REVISION HISTORY			
REV	DESCRIPTION	DATE	APPROVED

Replacement Diaphragm for :-
 OEM PART = 600025-M-5E
 USED ON 1" (DN25) Diaphragm Valve

	NAME	DATE
DRAWN	M. MC KEON	08/30/14
CHECKED		

Material -
EPDM BACKING
PTFE - DIAPHRAGM

Complies with CFR 177.2600
 and Conforms to
 USP Class VI Biological Reactivity
 Tests Section #87 and #88



TITLE
DD10-GTFM-E

SIZE	FOOT PRINT DIMENSIONS	REV
A		B

SCALE: 1 : 1	ECO:0605	SHEET 1 OF 1
--------------	----------	--------------

Disclaimer - Diaphragm Direct® does not manufacture, represent, nor sell OEM valves or diaphragms manufactured by any other company. Diaphragm Direct® brand diaphragms are not sponsored by any other manufacturers. Any name, model, part number, brand, image, material or referral is for descriptive purposes only. Diaphragm Direct® brand replacement diaphragms are guaranteed to fit OEM equipment and meet or exceed OEM specifications. Diaphragm Direct® brand replacement diaphragms are covered by the standard Diaphragm Direct® limited product warranty.